

7(a). HCCS Current State Hiring Process (Competitive Hires) – Prepare for Entrance on Duty

Staffing Vendor

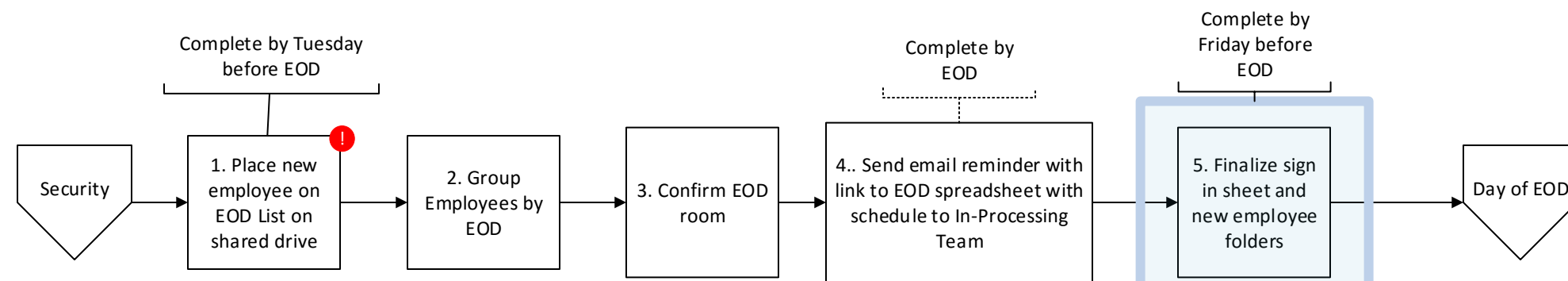

In Processing Team

5. Prepare In-Processing briefing schedule and print out SharePoint documents

Legend:

- ! Standard Vendor Communication
- Start of End Process
- Decision Point
- Alternate Process

In-Processing Team:

- Human Resource Business Partners (HRBPs),
- Benefits and Payroll
- Office of Security (OSY)
- Security Building Briefing
- Transit
- IT
- Office of General Counsel Ethics Office
- Budget
- Additional Presenters